

Application Note AN-016

Driving Contactors with external PWM

Gigavac offers the GX14, GX23, and GV200 with built-in PWM economizer (coil option M or N). For those customers that prefer to use their own PWM circuit, Gigavac can also provide the contactor without the internal economizer (coil option P or Q). This application note provides additional details on how to drive the contactor to insure that it can meet published ratings.

PWM

The GX14, GX23, and GV200 require an initial 50-100ms current/voltage pulse in order to fully close the contacts. Two control methods are typically used for PWM: current or voltage.

Voltage Controlled:

For Voltage Control the coil voltage is kept constant with varying input voltage. Since coil resistance varies with temperature the coil current will change with temperature. Table 1 and 2 show the design parameters for voltage control. Coil Current is at recommended voltage and is shown over the temperature range as a reference.

Table 1. Design Parameters for P coil, Voltage control

	Recommended Coil Voltage (V)	Allowable Coil Voltage Range (V)
During Pickup (first 50-100ms)	12	9-16
During Hold	2.6	2.1-3.5

Coil Current -55C (A)	Coil Current 25C (A)	Coil Current 125C (A)
3.33 (1.80- 4.44)	2.31 (1.73-3.08)	1.67 (1.25-2.22)
.72 (.58-.97)	.50 (.40-.67)	.36 (.29-.49)

Table 2. Design Parameters for Q coil, Voltage control

	Recommended Coil Voltage (V)	Allowable Coil Voltage Range (V)
During Pickup (first 50-100ms)	48	36-64
During Hold	11	8.5-14.5

Coil Current -55C (A)	Coil Current 25C (A)	Coil Current 125C (A)
.82 (.61-1.09)	.57 (.42-.76)	.41 (.31-.55)
.19 (.14-.25)	.13 (.10-.17)	.09 (.07-.12)

Current Feedback:

For Current feedback the coil current is kept constant with varying input voltage. Since coil resistance varies with temperature the coil voltage will change with temperature. Table 3 and 4 shows the design parameters for current feedback. Coil Voltage is at recommended coil current and is shown over the temperature range as a reference.

Table 3. Design Parameters for P coil, Current feedback

	Recommended Coil Current (A)	Allowable Coil Current Range (A)	Coil Voltage -55C (V)	Coil Voltage 25C (V)	Coil Voltage 125C (V)
During Pickup (first 50-100ms)	1.67	1.25-2.22	6.1 (4.5-8.0)	8.7 (6.7-11.5)	12 (9-16)
During Hold	.36	.29-.49	1.3 (1.1-1.8)	1.9 (1.5-2.5)	2.6 (2.1-3.5)

Table 4. Design Parameters for Q coil, Current feedback

	Recommended Coil Current (A)	Allowable Coil Current Range (A)	Coil Voltage -55C (V)	Coil Voltage 25C (V)	Coil Voltage 125C (V)
During Pickup (first 50-100ms)	.41	.31-.55	24 (18-32)	35 (26-47)	48 (36-64)
During Hold	.09	.07-.12	5.2 (4.4-7.2)	7.6 (6.0-10.0)	11 (8.5-14.5)

Coil Details

Table 5 shows coil resistance and inductance for the P and Q coils.

Table 5. Coil Details

Coil Designator	Coil Resistance Ohms at 25°C	Coil Inductance mH
P	5.2 +/-5%	18.5 +/-5%
Q	80 +/-5%	250 +/-5%

Fast Dropout

Gigavac contactors require that coil current does not flow when the contacts open. Since PWM circuits require a freewheeling or fly back diode be placed across the coil this diode must be removed from the circuit when the contacts are opened. Figure 1 shows a typical circuit that can be used to turn off a FET in the freewheeling path. C1 and R2 should be set to allow the FD FET to remain on while the PWM FET is running but decay within a few ms to shut off the FD FET before the contactor begins to open.

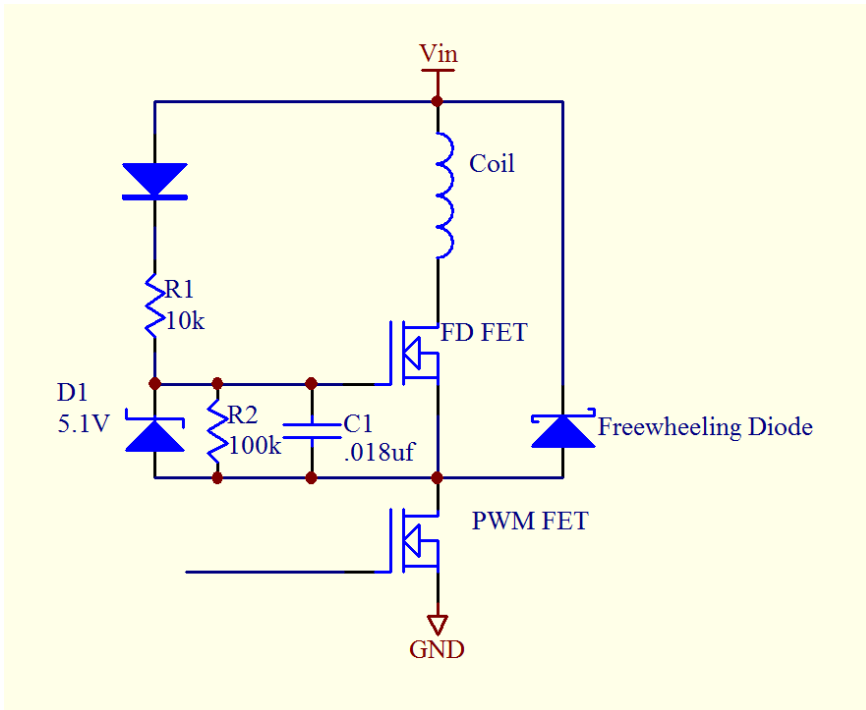

Figure 1. Fast dropout circuit

If you have any questions you can always call us at 805-684-8401.