

GXNC14

12 to 750 Vdc/Vac

Normally Closed EPIC® Hermetic Sealed DC and AC Contactor - 350+ Amp Power Switching

RoHS Compliant, all date codes



Patent Pending



File E320908

All contact ratings and coil versions may not be UL recognized.

Contact GIGAVAC for a copy of the applicable sections of the test report.

FEATURES

- **Normally closed version of GIGAVAC GX14.**
- **Chassis level UL508 sized power terminals** – No need for specially routed power cables, special bus bars, or special lugs.
- **Rugged EPIC® Seal rated to 175°C** – Reduced risk of fire or meltdown in over current conditions. The same technology used for advanced aerospace programs.
- **Hermetically Sealed** – Designed to meet: UL1604 for Class I & II, Div 2 and Class III for use in hazardous locations, IP67 for temporary water immersion for 30 min, SAE J1171 - external ignition protection, and ISO8846 for protection against ignition around flammable gasses.
- **High Efficiency Dual DC Coils** – Very low 12 or 24 VDC continuous coil power with no EMI emissions or cross-talk on your system control power. Ideal for battery powered systems or where low power is needed.
- **Built-in coil suppression for all DC coils** – Saves you engineering time and parts cost to add external coil suppression.
- **Stainless steel hardware and mounting inserts**, for years of corrosion free service.
- **UL508 ambient compliant to 75°C** but can operate continuously at 85°C with a higher terminal temperature rise of 60°C. Can also operate up to 125°C in special cases - contact GIGAVAC for details.
- **Not position sensitive** – can be mounted in any position for ease of installation

UL COMPLIANT DC & AC ESTIMATED CONTACT POWER SWITCHING RATINGS

Make & Break Resistive Current with 400 KCMil cable and 50° terminal temp rise	Contact Voltages & Life Cycle Ratings DC or 50/60 Hz AC					
	24 V	48 V	72 V	120 V	350 V	750 V
350A - (75° C Ambient) 1/	112,500	75,000	37,500	15,000	3,000	750
225A - (75° C Ambient) 1/	150,000	100,000	50,000	20,000	4,000	1,000
150A - (75° C Ambient) 1/	180,000	120,000	60,000	24,000	4,800	1,200
125A - (75° C Ambient) 1/	225,000	150,000	75,000	30,000	6,000	1,500
100A - (75° C Ambient) 1/	300,000	200,000	100,000	40,000	8,000	2,000
75A - (75° C Ambient) 1/	435,000	290,000	145,000	58,000	11,600	2,900
50A - (75° C Ambient) 1/	750,000	500,000	250,000	100,000	20,000	5,000
30A - (75° C Ambient) 1/	900,000	600,000	300,000	120,000	24,000	6,000
20A - (75° C Ambient) 1/	1,000,000	700,000	350,000	140,000	28,000	7,000
400A - (50° C Ambient) 2/	90,000	60,000	30,000	12,000	2,400	600
Max Break A, 2 cycles (75° C Ambient) 1/	1,500A	1,400A	1,300A	1,200A	1,100A	1,000A
Max Make, 10 cycles (75° C Ambient) 1/	1,000A	900A	800A	700A	600A	500A

Electrical life rating is based on resistive load with 27µH maximum inductance in circuit. Because your application may be different, we suggest you test the contactor in your circuit to verify life is as required.

End of life is defined as when the dielectric, insulation resistance or contact resistance exceeds the specifications listed.

1/ Assumes UL508 ratings with 400 KCMil cables, UL508 max ambient temperature of 75°C as shown, and max. UL508 terminal temperature rise of 50°C.

At 85°C ambient, contactor can also meet all of its 75°C specifications but the terminal temperature can rise can be up to 60°C, which is higher than the 50°C rise allowed by UL508 and can be higher than some cable insulation ratings.

2/ Assumes UL508 ratings with 400 KCMil cables, at a lower 50°C UL508 ambient temperature, and max. UL508 terminal temperature rise of 50°C.

UL COMPLIANT DC & AC CONTACT CURRENT CARRY RATINGS		
		75°C / 50°C
Cable size 1/	KCmil	400
Continuous, UL508 Max 1/	Amp	350 / 400
10 seconds (1 time)	Amp	525 / 710
100 Seconds (1 time)	Amp	390 / 510
300 Seconds (1 time)	Amp	350 / 400
Starter Carry – Inrush 250 ms (10 repeats 1/ 2/)	Amp	NA / 2,000
Starter Carry - Cranking 10 sec (10 repeats 1/ 2/)	Amp	NA / 500
Maximum terminal Temp, Continuous	Deg C	175
Maximum terminal Temp, Intermittent	Deg C	225

1/ Assumes UL508 ratings with 400 KCmil cables, ambient max. UL508 temperature of 75°C, and max. UL508 terminal temperature rise of 50°C. Contactor can also carry the higher currents shown on page 2 at 50°C ambient, and meet all of the UL508 requirements.

Contactors meet all of its published specifications at 85°C ambient, but terminal temperature can rise 60°C, which is higher than the 50°C allowed by UL508.

The maximum terminal temperature rating is 175°C, which means much higher currents than shown on page 2 can be carried and switched. However, this temperature is much higher than most cable insulation ratings, which mean busbars must be used. Contact GIGAVAC for assistance for higher current applications.

2/ Rating consists of combined inrush + cranking current at the times specified, with 2 seconds off between cycles. This is higher current than is required for UL1107 for marine battery switches.

COIL RATINGS		
Coil Voltage (Nominal)	12Vdc	24Vdc
Coil P/N Designation	B	C
Coil Voltage (Max) 1/	15	30
In-Rush Current Max (75 ms) – Amps 2/ 3/	4.0	1.7
Hold Current after in-rush (Avg.) - Amps 3/	0.30	0.12
Hold Power after in-rush (Avg.) – Watts 3/	3.6	3.0
Pick-up, Volts, Max 2/ 4/ 5/	8.0	16.0
Hold, Volts, Min 5/	5.0	10.0
Drop-Out, Volts, Min 5/	0.2	0.5
Coil Back EMF (volts) 6/	45	45

Ratings are at 25°C. For specific values at other temperatures, please [contact GIGAVAC](#).

1/ Because the contactor is operated by a coil that changes resistance with temperature, the maximum coil voltage will be lower than indicated at temperatures above 25C, and higher than indicated at temperatures below 25C.

2/ Contactor has two coils. Both are used for pull-in, and then in approximately 75 milliseconds, one coil is electronically removed from the coil drive circuit. The remaining coil supplies low continuous hold power sufficient for the contactor to meet all of its specified performance specifications. This provides the lowest coil power possible without the use of PWM electronics that have been known to cause EMI emissions and/or cross-talk on your system control power.

3/ Because the contactor is operated by a coil that changes resistance with temperature, and because Nominal Coil voltage has been assumed for the In-Rush, Hold Current and Hold Power specifications, Current/Wattage will be lower than indicated at temperatures above 25C and higher than indicated at temperatures below 25C.

4/ For Pick-up testing of contactors with dual coils, the voltage can not be ramped up slowly, but must be applied instantly to at least the maximum pull-in voltage or current. Otherwise, the contactor will not pick-up.

5/ Because the contactor is operated by a coil that changes resistance with temperature, Pick-up Voltage, Hold Voltage, and Drop Out Voltage will be lower than indicated at temperatures below 25C and higher than indicated at temperatures above 25C.

6/ These DC coils have built-in coil suppression. The use of additional external coil suppression can slow the release time and invalidate the life cycle ratings, or can cause the contactor not to be able to interrupt the maximum current specified. If lower coil back EMF is required, please [contact GIGAVAC](#) for assistance.

PRODUCT SPECIFICATIONS		
Specifications	Units	Specifications
Contact Arrangement (main)	Form Y	SPST-NC
Mechanical Life	cycles	1 million
Contact Resistance Max @ rated carry current Typical @ rated carry current	mohms mohms	.4 .15 to .3
Operate time (Break), 25°C - (includes arc time at max. break current)		
Release time	ms	12
Close (includes bounce) Max	ms	20
Close (includes bounce) Typical	ms	13
Bounce on close, Max	ms	7
Insulation Resistance	Mohms	100 1/
Dielectric at sea level (leakage < 1mA)	VRMS	2,500
Shock	G's peak	20
Vibration, Sinusoidal (500-2000 Hz peak)	G's	15
Operating ambient Temp Range	°C	-55 to +85 2/
Storage ambient Temp Range	°C	-70 to +175
Weight, Typical	Kg (Lb)	0.50/(1.1)

1/ 50 Mohms after life.

2/ Contactor can operate up to 125°C in special cases - contact GIGAVAC for details.

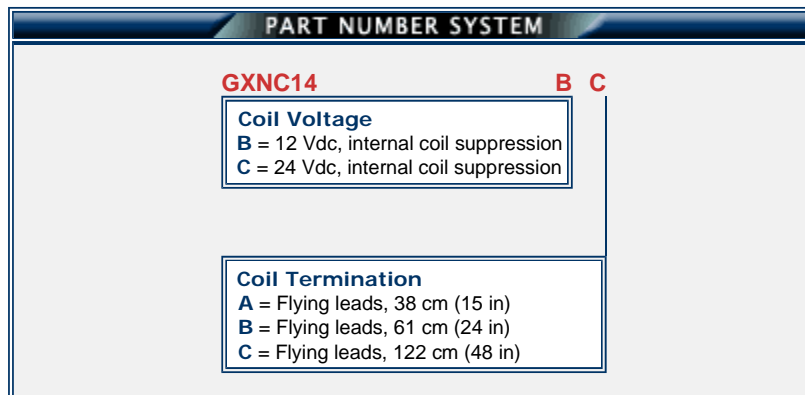

MOUNTING

M5 or NO.10 SCREWS
TORQUE 1.7-4Nm [15-35in-lb]

CASE MATERIAL

Zytel FR50

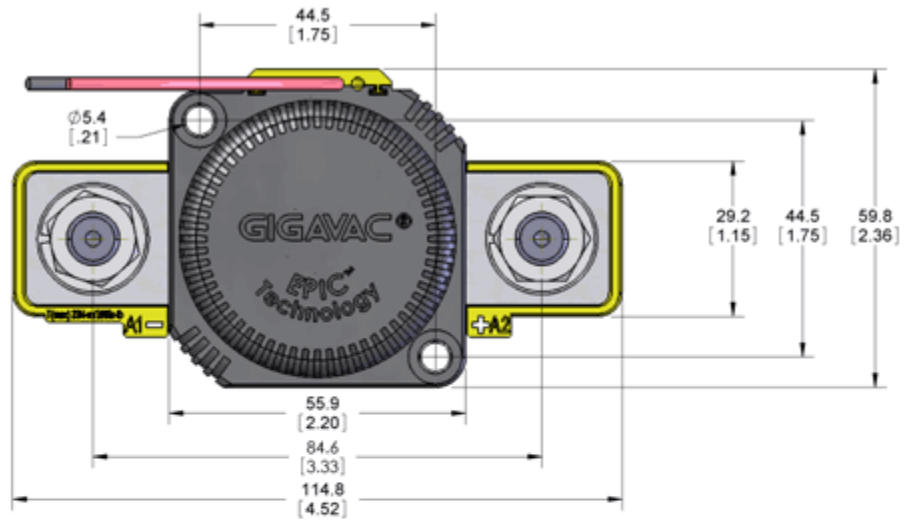

POWER CONNECTION

HARDWARE INCLUDED:
STAINLESS M10X1.5 BOLT
STAINLESS M10X1.5 NUT
STAINLESS LOCK WASHER
STAINLESS FLAT WASHER
TORQUE 11-23Nm [100-200 in-lb]

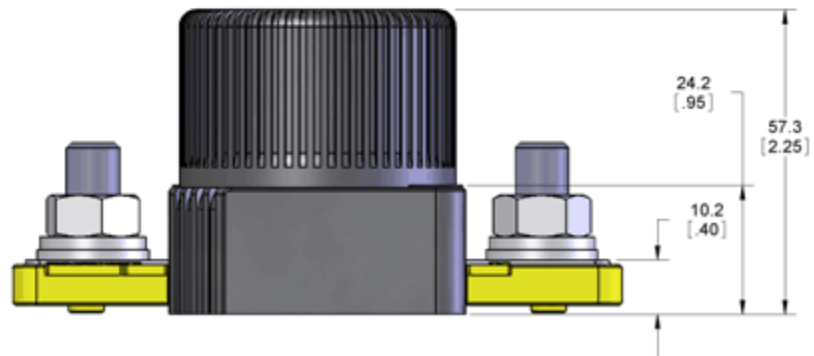

DC DUAL COIL



BLACK X2
COIL (-)
RED X1
COIL (+)

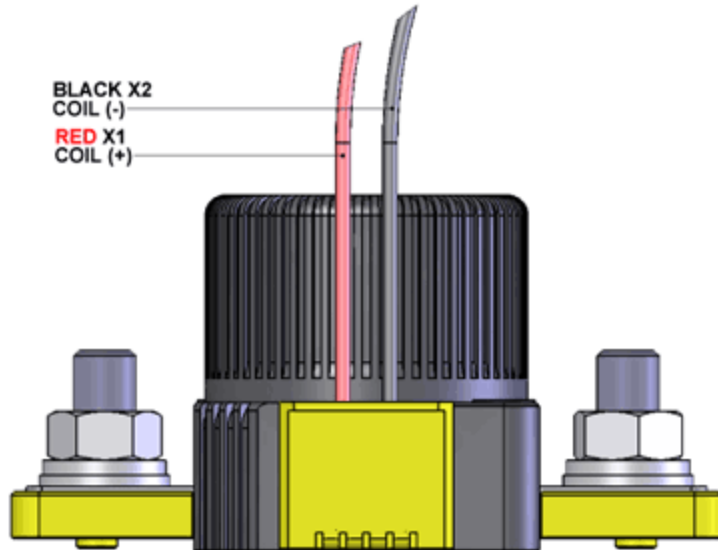

WIRE SPEC: SILICONE, 22AWG, -40C-150C, UL: VW-1

Power contacts

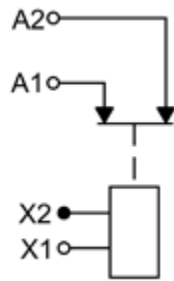

Application Information:

1. **WARNING** - When using more than one lug on a power terminal, make sure the primary power is closest to the contactor busbar, with the lower current lug on top, then the washer, then the lock washer, then the nut. **Improper order can cause severe over-heating resulting in the possible melting of the connecting cable insulation.**

2. [EPIC®](#) sealing technology

3. [Relay Schematics and Forms](#)

01/11/11



GIGAVAC® - P.O. Box 4428 - Santa Barbara, CA 93140-4428 - ph +(805) 684-8401 - +(805) 755-2000
fx +(805) 684-8402 - info@gigavac.com - www.gigavac.com - ©Copyright 2003-2011 GIGAVAC, LLC.