

GX23

12 to 750 Vdc/Vac

EPIC® Hermetic Sealed DC and AC Contactor - 350+ Amp Power Switching

RoHS Compliant, all date codes



Patent Pending

FEATURES

- **Rugged EPIC® Ceramic-to-Metal Seal Rated to 175°C** – Reduced risk of fire or meltdown in over-current conditions compared to the less-durable epoxy seal.
- **EPIC® Hermetic Seal** – Designed to meet UL1604 for Class I & II, Div 2 and Class III for use in hazardous locations, IP67 for temporary water immersion for 30 min, SAE J1171 - external ignition protection, and ISO8846 for protection against ignition around flammable gasses.
- **High Efficiency Dual Coils** – Unlike the PWM coil economizer found in other contactors that can cause cross-talk on your system control power or radiate noise, the GIGAVAC GX23 uses two coils. One drops out after the contactor is energized providing low power to keep the contactor energized.
- **No Exposed Coil Electronics** – The GIGAVAC GX23 can operate almost anywhere, even under water - unlike other contactors with exposed PWM coil electronics that can fail in harsh environments.
- **Built-in Power Terminal Safety Cover** – Extra assurance of a safer connection without the use of metal fastening screws. Can also be easily permanently removed in applications where not needed.
- **Fully RoHS Compliant** – The GX23 is fully compliant and is better for the environment and future generations.
- **Built-in coil suppression** – Saves you THE engineering time and parts cost to add external coil suppression.
- **Clear & Precise Specifications** – No guessing to SEE if GIGAVAC's GX23 contactor will work in your application.

Notice for New Applications

If your application is 100A or higher we suggest you consider GIGAVAC's 150 Amp [GX11](#), 225 Amp [GX12](#), or 350Amp [GX14](#) that have convenient chassis level bus bar type power terminations that are designed to accept larger size cables and lugs.

UL COMPLIANT DC & AC ESTIMATED CONTACT POWER SWITCHING RATINGS						
Make & Break Resistive Current with 400 KCmil cable and 50° terminal temp rise	Contact Voltages & Life Cycle Ratings DC or 50/60 Hz AC					
	24 V	48 V	72 V	120 V	350 V	750 V
350A - (75° C Ambient) 1/	75,000	56,250	26,250	15,000	3,000	750
225A - (75° C Ambient) 1/	100,000	75,000	35,000	20,000	4,000	1,000
150A - (75° C Ambient) 1/	120,000	90,000	42,000	24,000	4,800	1,200
125A - (75° C Ambient) 1/	150,000	112,500	52,500	30,000	6,000	1,500
100A - (75° C Ambient) 1/	200,000	150,000	70,000	40,000	8,000	2,000
75A - (75° C Ambient) 1/	290,000	217,500	101,500	58,000	11,600	2,900
50A - (75° C Ambient) 1/	500,000	375,000	175,000	100,000	20,000	5,000
30A - (75° C Ambient) 1/	600,000	450,000	210,000	120,000	24,000	6,000
20A - (75° C Ambient) 1/	700,000	525,000	245,000	140,000	28,000	7,000
400A - (50° C Ambient) 2/	60,000	45,000	21,000	12,000	2,400	600
Max Break A, 2 cycles (75° C Ambient) 1/	3,900A	3,600A	2,900A	2,200A	1,980A	1,320A
Max Make, 10 cycles (75° C Ambient) 1/	1,000A	900A	800A	700A	600A	500A

Electrical life rating is based on resistive load with 27µH maximum inductance in circuit. Because your application may be different, we suggest you test the contactor in your circuit to verify life is as required.

End of life is defined as when the dielectric, insulation resistance or contact resistance exceeds the specifications listed.

1/ Assumes UL508 ratings with 400 KCmil cables, UL508 max ambient temperature of 75°C as shown, and max. UL508 terminal temperature rise of 50°C. For less than 100A, standard UL recommended cable sizes are assumed.

At 85°C ambient, contactor can also meet all of its 75°C specifications but the terminal temperature can rise can be up to 60°C, which is higher than the 50°C rise allowed by UL508 and can be higher than some cable insulation ratings.

2/ Assumes UL508 ratings with 400 KCmil cables, at a lower 50°C UL508 ambient temperature, and max. UL508 terminal temperature rise of 50°C.

UL COMPLIANT DC & AC CONTACT CURRENT CARRY RATINGS		
		75° C / 50° C
Cable size 1/	KCmil	400
Continuous, UL508 Max 1/	Amp	350 / 400
10 seconds (1 time)	Amp	525 / 710
100 Seconds (1 time)	Amp	390 / 510
300 Seconds (1 time)	Amp	350 / 400
Starter Carry – Inrush 250 ms (10 repeats 1/ 2/)	Amp	NA / 2,000
Starter Carry - Cranking 10 sec (10 repeats 1/ 2/)	Amp	NA / 500
Maximum terminal Temp, Continuous	Deg C	175
Maximum terminal Temp, Intermittent	Deg C	225

1/ Assumes UL508 ratings with 400 KCmil cables, ambient max. UL508 temperature of 75°C, and max. UL508 terminal temperature rise of 50°C. Contactor can also carry the higher currents shown on page 2 at 50°C ambient, and meet all of the UL508 requirements.

Contactor meets all of its published specifications at 85°C ambient, but terminal temperature can rise 60°C, which is higher than the 50°C allowed by UL508.

The maximum terminal temperature rating is 175°C, which means much higher currents than shown on page 2 can be carried and switched. However, this temperature is much higher than most cable insulation ratings, which mean busbars must be used. Contact GIGAVAC for assistance for higher current applications.

2/ Rating consists of combined inrush + cranking current at the times specified, with 2 seconds off between cycles. This is higher current than is required for UL1107 for marine battery switches.

COIL RATINGS			
Coil Voltage (Nominal)	12Vdc	24Vdc	48Vdc
Coil P/N Designation	B	C	F
Coil Voltage (Max) 1/	15	30	60
In-Rush Current Max (75 ms) – Amps 2/ 3/	4.0	1.7	0.9
Hold Current after in-rush (Avg.) - Amps 3/	0.30	0.12	0.06
Hold Power after in-rush (Avg.) – Watts 3/	3.6	3.0	2.9
Pick-up, Volts, Max 2/ 4/ 5/	7.5	15.0	40
Hold, Volts, Min 5/	5.0	10.0	22
Drop-Out, Volts, Min 5/	0.5	2.0	2
Coil Back EMF (volts) 6/	45	45	110

Ratings are at 25°C. For specific values at other temperatures, please [contact GIGAVAC](#).

1/ Because the contactor is operated by a coil that changes resistance with temperature, the maximum coil voltage will be lower than indicated at temperatures above 25C, and higher than indicated at temperatures below 25C.

2/ Contactor has two coils. Both are used for pull-in, and then in approximately 75 milliseconds, one coil is electronically removed from the coil drive circuit. The remaining coil supplies low continuous hold power sufficient for the contactor to meet all of its specified performance specifications. This provides the lowest coil power possible without the use of PWM electronics that have been known to cause EMI emissions and/or cross-talk on your system control power.

3/ Because the contactor is operated by a coil that changes resistance with temperature, and because Nominal Coil voltage has been assumed for the In-Rush, Hold Current and Hold Power specifications, Current/Wattage will be lower than indicated at temperatures above 25C and higher than indicated at temperatures below 25C.

4/ For Pick-up testing of contactors with dual coils, the voltage can not be ramped up slowly, but must be applied instantly to at least the maximum pull-in voltage or current. Otherwise, the contactor will not pick-up.

5/ Because the contactor is operated by a coil that changes resistance with temperature, Pick-up Voltage, Hold Voltage, and Drop Out Voltage will be lower than indicated at temperatures below 25C and higher than indicated at temperatures above 25C.

6/ These DC coils have built-in coil suppression. The use of additional external coil suppression can slow the release time and invalidate the life cycle ratings, or can cause the contactor not to be able to interrupt the maximum current specified. If lower coil back EMF is required, please [contact GIGAVAC](#) for assistance.

PRODUCT SPECIFICATIONS		
Specifications	Units	Specifications
Contact Arrangement (main)	Form X	SPST-NO
Contact Arrangement (Auxiliary) 1/	Form A	SPST-NO
Mechanical Life	cycles	1 million
Contact Resistance		
Max @ rated carry current	mohms	.4
Typical @ rated carry current	mohms	.15 to .3
Operate time, 25°C		
Close (includes bounce) Max	ms	20
Close (includes bounce) Typical	ms	13
Bounce on close, Max	ms	7
Release time (includes arc time at max. break current)	ms	12
Insulation Resistance	Mohms	100 2/
Dielectric at sea level (leakage < 1mA)	VRMS	2,500
Shock	G's peak	20
Vibration, Sinusoidal (500-2000 Hz peak)	G's	15
Operating ambient Temp Range	°C	-55 to +85 3/
Storage ambient Temp Range	°C	-70 to +175
Weight, Typical	Kg (Lb)	0.44/(0.98)

1/ Auxillary contact rating - 2A, 24Vdc Resistive load, 100,000 cycles. Minimum current is 1mA, 5V. The auxiliary contact is mechanically linked to the main power contacts.

2/ 50 Mohms after life.

3/ Contactor can operate up to 125°C in special cases - contact GIGAVAC for details.

PART NUMBER SYSTEM			
GX23	B	C	B
Coil Voltage B = 12 Vdc, internal coil suppression C = 24 Vdc, internal coil suppression F = 48 Vdc, internal coil suppression			
Coil Termination A = Flying leads, 38 cm (15 in) B = Flying leads, 61 cm (24 in) C = Flying leads, 122 cm (48 in)			
Auxiliary Contact (same length as coil wire selection) Blank = None B = SPST, Normally Open			

POWER CONNECTION

HARDWARE INCLUDED:
STAINLESS M8X1.25 STUD
STAINLESS M8X1.25 NUT
STAINLESS LOCK WASHER
STAINLESS FLAT WASHER

TORQUE 90 in-lb MAX

CASE MATERIAL

25-30% GF Nylon 6/6
UL94 V-O

MOUNTING

M5 or NO.10 SCREWS

TORQUE 1.7-4Nm [15-35in-lb]

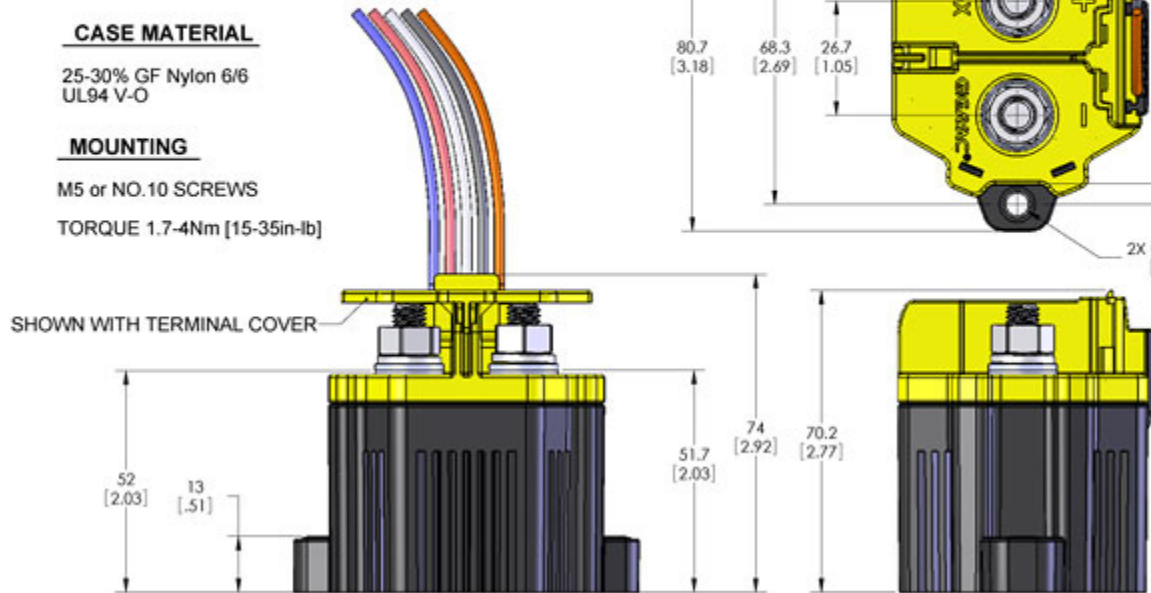
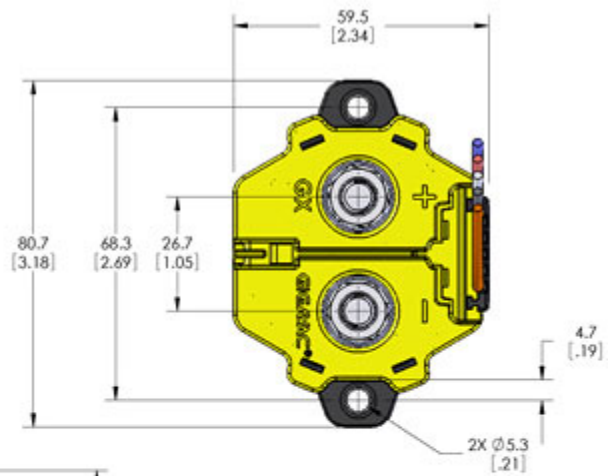

DC COIL SUPPRESSION

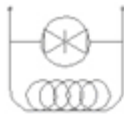

A/C COIL



BLACK X2
COIL (-)

WHITE T2
AUX

AUXILIARY OPTION

RED X1
COIL (+)

BLUE T1
AUX

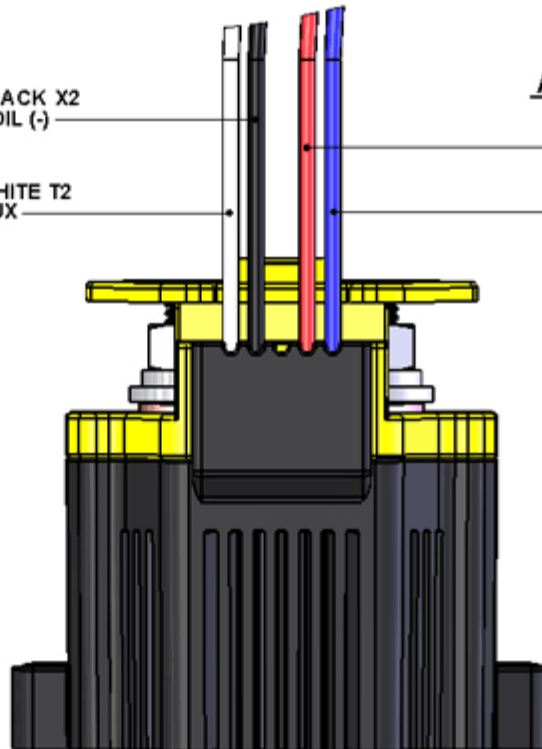

WIRE SPEC: SILICONE, 20AWG, -40C-150C, UL: VW-1

Power contacts

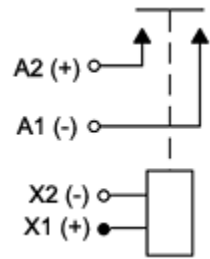

Auxiliary contacts (optional)

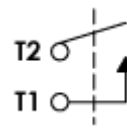

To Lift and Remove the Terminal Safety Cover:

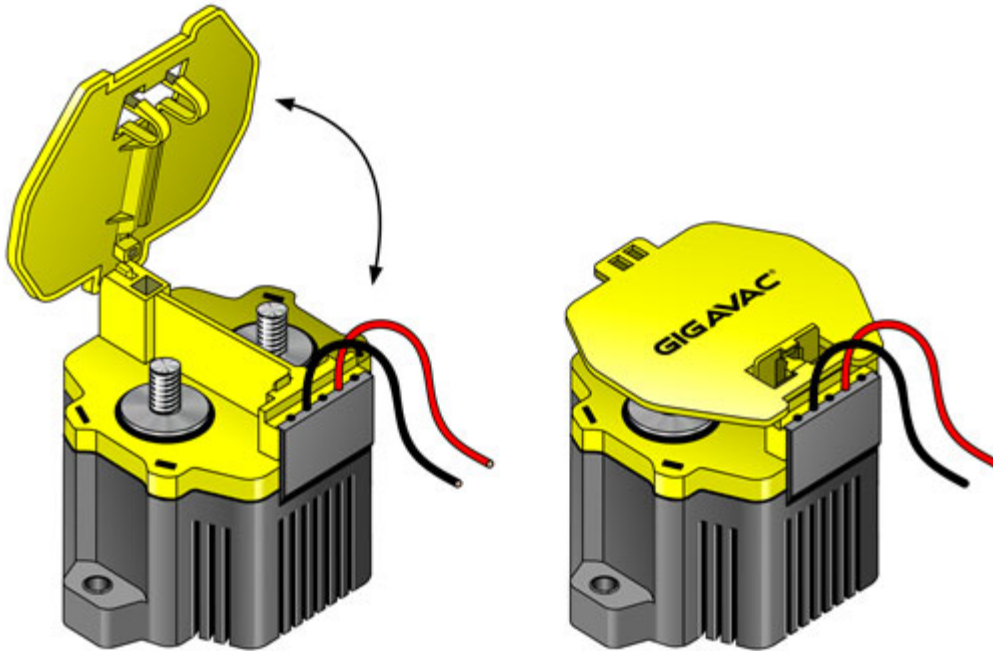

- A. Push the tab of the cover to unlock it.
- B. Lift the cover as shown. It will pivot on the rear pin.
- C. If needed, remove the cover by pulling it straight back as shown.
- D. To place the cover back in its original position, replace the cover as shown. Follow step C in reverse.
- E. The cover can now pivot down to close.
- F. Make sure to push the locking tab into place.

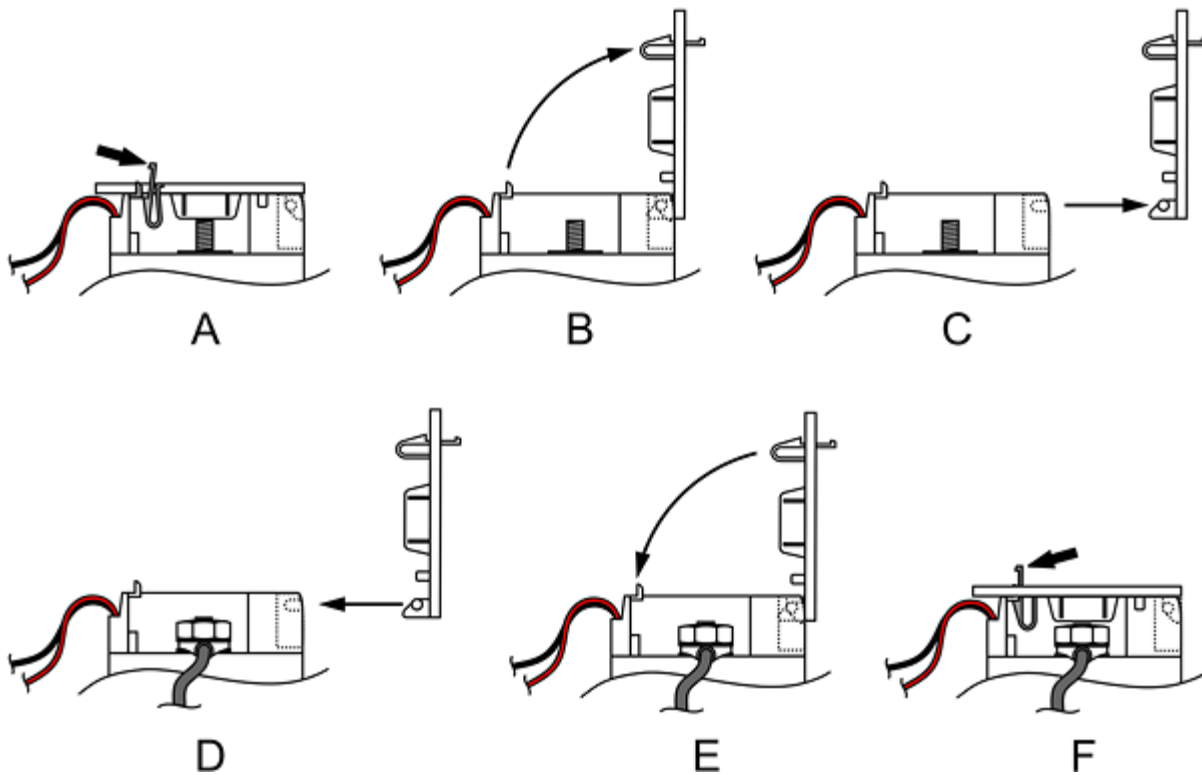

Application Information:

1. **WARNING** - When using more than one lug on a power terminal, make sure the primary power is closest to the contactor busbar, with the lower current lug on top, then the washer, then the lock washer, then the nut. **Improper order can cause severe over-heating resulting in the possible melting of the connecting cable insulation.**

2. **EPIC®** sealing technology

3. [Relay Schematics and Forms](#)

4. For the more user friendly panel level terminations, you may want to check out the GIGAVAC EPIC® sealed 125 Amp **GX11**, the 225 Amp **GX12**, or the 350 Amp **GX14**. The GX14 is nearly identical to the GX23 but has longer UL rated life and less maximum interrupt capability than the GX23. For a panel level terminal contactor with all of the GX23 ratings, [contact GIGAVAC](#).

06/24/11

