

GX200

12 to 900 Volts

Drop-in Alternative to Tyco/Kilovac* 500+ Amp EV200, plus a lot more ([Compare Products](#))

RoHS Compliant, all date codes



Patent Pending



File E320908

All contact ratings and coil versions may not be UL recognized.

[Contact GIGAVAC](#) for a copy of the applicable sections of the test report.

FEATURES

- **Form-Fit Alternate to Tyco/Kilovac* EV200.** See [Comparison](#).
- **Rugged EPIC® Ceramic-to-Metal Seal Rated to 175°C** – Reduced risk of fire or meltdown in over-current conditions compared to the less-durable EV200 epoxy seal.
- **EPIC® Hermetic Seal** – Designed to meet UL1604 for Class I & II, Div 2 and Class III for use in hazardous locations, IP67 for temporary water immersion for 30 min, SAE J1171 - external ignition protection, and ISO8846 for protection against ignition around flammable gasses.
- **High Efficiency Dual Coils** – Unlike the PWM coil economizer found in the EV200 that can cause cross-talk on your system control power or radiate noise, the GIGAVAC GX200 uses two coils. One drops out after the contactor is energized providing low power to keep the contactor energized.
- **No Exposed Coil Electronics** – The GIGAVAC GX200 can operate almost anywhere, even under water - unlike the Tyco EV200 with exposed PWM coil electronics that can fail in harsh environments.
- **Built-in Power Terminal Safety Cover** – Extra assurance of a safer connection without the use of metal fastening screws. Can also be easily permanently removed in applications where not needed.
- **Fully RoHS Compliant** – The GX200 is fully compliant and is better for the environment and future generations, unlike the EV200 that does not meet global RoHS standards.
- **Built-in coil suppression** – Saves you THE engineering time and parts cost to add external coil suppression.
- **Clear & Precise Specifications** – No guessing to SEE if GIGAVAC's GX200 contactor will work in your application.

Notice for New Applications

Before selecting the GX200 for new applications, we suggest you first consider GIGAVAC's 150 Amp [GX11](#), 225 Amp [GX12](#), or 350Amp [GX14](#) that accept standard size wire lugs with convenient chassis level power terminations. The EV200 was originally designed for only 200 Amps with appropriate sized terminals and pads. Over time, the EV200 current rating was increased with the assumption the user would use multiple wire lugs or use bus bars to carry the higher current. For more information about the EV200/GX200 current ratings, see the discussion under [compare products](#).

EV200 EQUIVALENT DC RATINGS

In order to allow you a comparison to the Tyco/Kilovac* EV200, these GX200 ratings assume an ambient temp of 85°C, 400Kcmil power cables, and a maximum terminal temperature of 150°C, which is higher than 125° allowed by UL and higher than the insulation temperature rating of some wire. This means above about 400A continuous using 150° as the maximum terminal temperature, the user must provide cables or bus bars that will pull heat from the terminals, or the ambient temperature must be reduced, or both. For UL compliant ratings, see "UL Compliant DC & AC... Ratings" below. For more information about contact ratings, see the [Product Comparison](#).

Estimated DC Resistive Load Make & Break Life Cycle Ratings

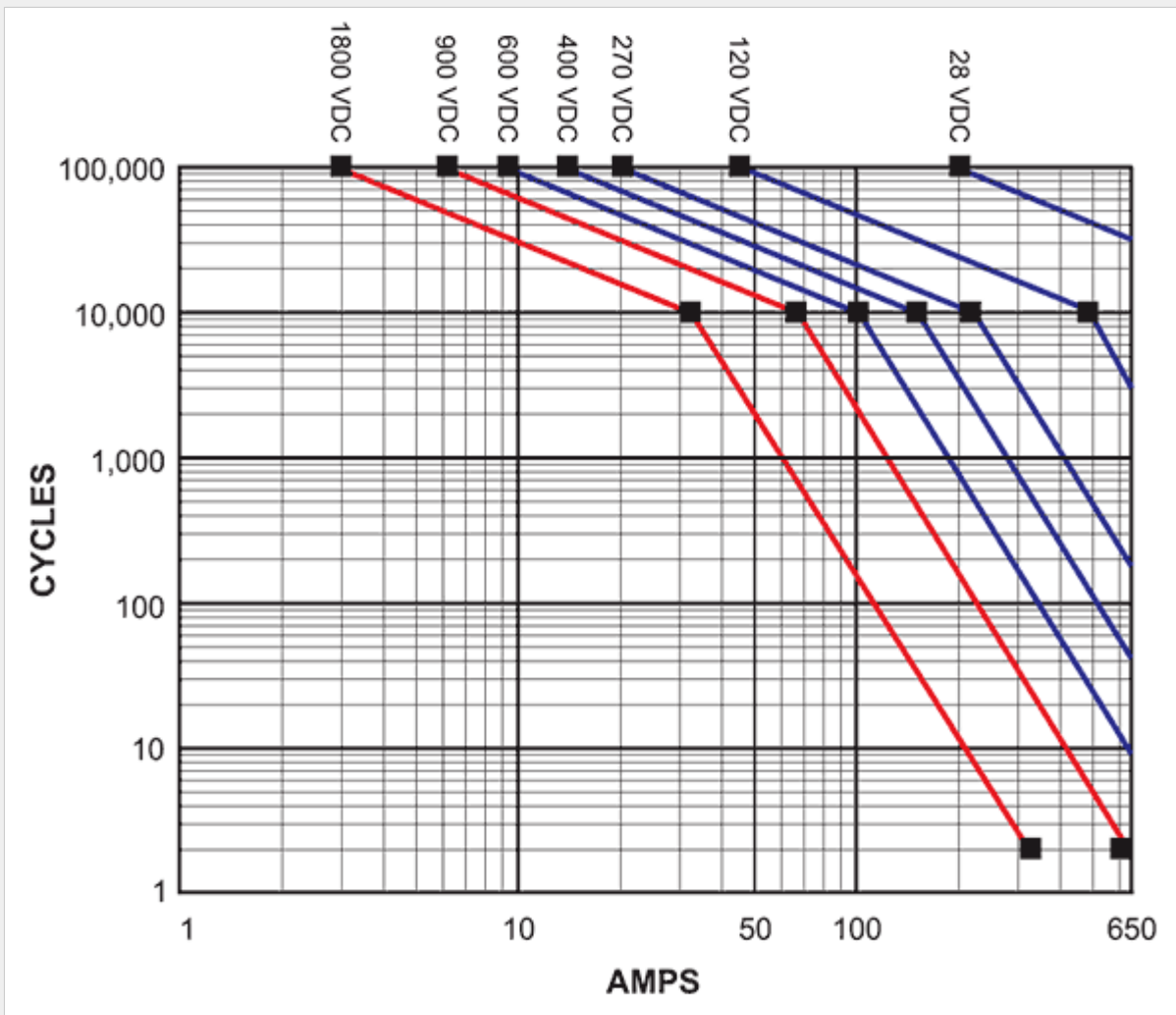

Notes:

1. Estimates are based on extrapolated data. Because every application is different, user should verify performance in the actual application.
2. **For the 1,800 Volt and 900 Volt ratings**, the dielectric rating of the GX200 and EV200 contactors is less than the industry accepted standard of two times the source voltage, plus 1,000 volts. For details, see discussion under "Understanding Contactor Contact Ratings" on [Compare Products](#) page.

3. End of life is when the insulation resistance between terminals falls below 50 megohms @500Vdc.
4. The maximum make current is 650Adc, at which time welding may occur.

Typical 350 Vdc Capacitive “Make Only” Ratings for pre-charged capacitors used in Motor Controller & Inverters

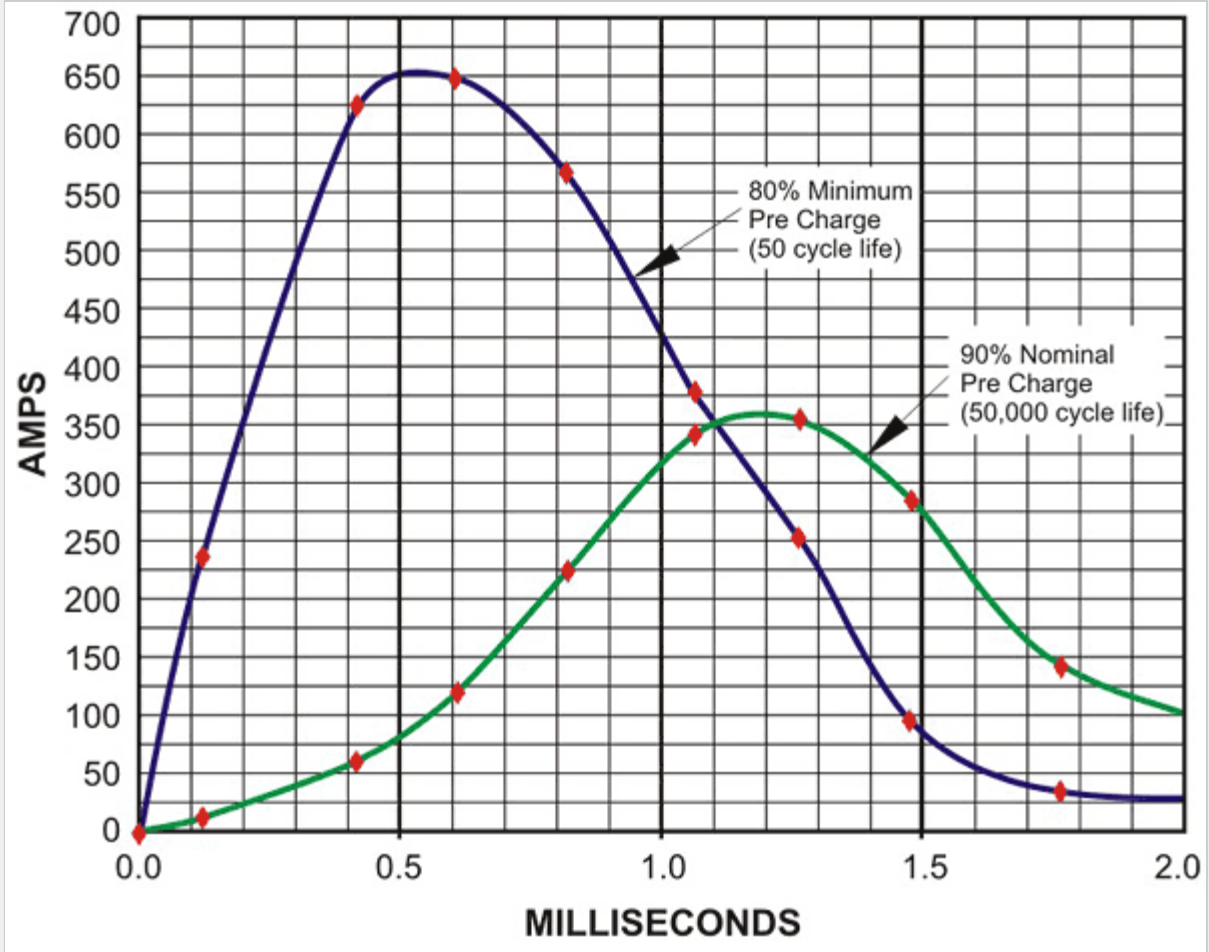

Notes:

1. Maximum Make current is 650 Amp.

UL COMPLIANT DC & AC ESTIMATED CONTACT POWER SWITCHING RATINGS					
Make & Break Resistive Current with 400 KCmil cable and 50° terminal temp rise	Contact Voltages & Life Cycle Ratings DC or 50/60 Hz AC				
	24 V	48 V	72 V	120 V	350 V
350A - (75° C Ambient) 1/	75,000	56,250	26,250	15,000	3,000
225A - (75° C Ambient) 1/	100,000	75,000	35,000	20,000	4,000
150A - (75° C Ambient) 1/	120,000	90,000	42,000	24,000	4,800
125A - (75° C Ambient) 1/	150,000	112,500	52,500	30,000	6,000
100A - (75° C Ambient) 1/	200,000	150,000	70,000	40,000	8,000
75A - (75° C Ambient) 1/	290,000	217,500	101,500	58,000	11,600
50A - (75° C Ambient) 1/	500,000	375,000	175,000	100,000	20,000
30A - (75° C Ambient) 1/	600,000	450,000	210,000	120,000	24,000
20A - (75° C Ambient) 1/	700,000	525,000	245,000	140,000	28,000
400A - (50° C Ambient) 2/	60,000	45,000	21,000	12,000	2,400
Max Break A, 2 cycles (75° C Ambient) 1/	3,900A	3,600A	2,900A	2,200A	1,980A
Max Make, 10 cycles (75° C Ambient) 1/	1,000A	900A	800A	700A	600A

Electrical life rating is based on resistive load with 27µH maximum inductance in circuit. Because your application may be different, we suggest you test the contactor in your circuit to verify life is as required.

End of life is defined as when the dielectric, insulation resistance or contact resistance exceeds the specifications listed.

1/ Assumes UL508 ratings with 400 KCmil cables, UL508 max ambient temperature of 75°C as shown, and max. UL508 terminal temperature rise of 50°C.

At 85°C ambient, contactor can also meet all of its 75°C specifications but the terminal temperature can rise can be up to 60°C, which is higher than the 50°C rise allowed by UL508 and can be higher than some cable insulation ratings.

2/ Assumes UL508 ratings with 400 KCmil cables, at a lower 50°C UL508 ambient temperature, and max. UL508 terminal temperature rise of 50°C.

UL COMPLIANT DC & AC CONTACT CURRENT CARRY RATINGS		
		75° C / 50° C
Cable size 1/	KCmil	400
Continuous, UL508 Max 1/	Amp	350 / 400
10 seconds (1 time)	Amp	525 / 710
100 Seconds (1 time)	Amp	390 / 510
300 Seconds (1 time)	Amp	350 / 400
Starter Carry – Inrush 250 ms (10 repeats 1/ 2/)	Amp	NA / 2,000
Starter Carry - Cranking 10 sec (10 repeats 1/ 2/)	Amp	NA / 500
Maximum terminal Temp, Continuous	Deg C	175
Maximum terminal Temp, Intermittent	Deg C	225

1/ Assumes UL508 ratings with 400 KCmil cables, ambient max. UL508 temperature of 75°C, and max. UL508 terminal temperature rise of 50°C. Contactor can also carry the higher currents shown on page 2 at 50°C ambient, and meet all of the UL508 requirements.

Contactor meets all of its published specifications at 85°C ambient, but terminal temperature can rise 60°C, which is higher than the 50°C allowed by UL508.

The maximum terminal temperature rating is 175°C, which means much higher currents than shown on page 2 can be carried and switched. However, this temperature is much higher than most cable insulation ratings, which mean busbars must be used. Contact GIGAVAC for assistance for higher current applications.

2/ Rating consists of combined inrush + cranking current at the times specified, with 2 seconds off between cycles. This is higher current than is required for UL1107 for marine battery switches.

COIL RATINGS			
Coil Voltage (Nominal)	12Vdc	24Vdc	48Vdc
Coil P/N Designation	B	C	F
Coil Voltage (Max) 1/	15	30	60
In-Rush Current Max (75 ms) – Amps 2/ 3/	4.0	1.7	0.9
Hold Current after in-rush (Avg.) - Amps 3/	0.30	0.12	0.06
Hold Power after in-rush (Avg.) – Watts 3/	3.6	3.0	2.9
Pick-up, Volts, Max 2/ 4/ 5/	7.5	15.0	40
Hold, Volts, Min 5/	5.0	10.0	22
Drop-Out, Volts, Min 5/	0.5	2.0	2
Coil Back EMF (volts) 6/	45	45	110

Ratings are at 25°C. For specific values at other temperatures, please [contact GIGAVAC](#).

1/ Because the contactor is operated by a coil that changes resistance with temperature, the maximum coil voltage will be lower than indicated at temperatures above 25C, and higher than indicated at temperatures below 25C.

2/ Contactor has two coils. Both are used for pull-in, and then in approximately 75 milliseconds, one coil is electronically removed from the coil drive circuit. The remaining coil supplies low continuous hold power sufficient for the contactor to meet all of its specified performance specifications. This provides the lowest coil power possible without the use of PWM electronics that have been known to cause EMI emissions and/or cross-talk on your system control power.

3/ Because the contactor is operated by a coil that changes resistance with temperature, and because Nominal Coil voltage has been assumed for the In-Rush, Hold Current and Hold Power specifications, Current/Wattage will be lower than indicated at temperatures above 25C and higher than indicated at temperatures below 25C.

4/ For Pick-up testing of contactors with dual coils, the voltage can not be ramped up slowly, but must be applied instantly to at least the maximum pull-in voltage or current. Otherwise, the contactor will not pick-up.

5/ Because the contactor is operated by a coil that changes resistance with temperature, Pick-up Voltage, Hold Voltage, and Drop Out Voltage will be lower than indicated at temperatures below 25C and higher than indicated at temperatures above 25C.

6/ These DC coils have built-in coil suppression. The use of additional external coil suppression can slow the release time and invalidate the life cycle ratings, or can cause the contactor not to be able to interrupt the maximum current specified. If lower coil back EMF is required, please [contact GIGAVAC](#) for assistance.

PRODUCT SPECIFICATIONS		
Specifications	Units	Specifications
Contact Arrangement (main)	Form X	SPST-NO
Contact Arrangement (Auxiliary) 1/	Form A	SPST-NO
Mechanical Life	cycles	1 million
Contact Resistance		
Max @ rated carry current	mohms	.4
Typical @ rated carry current	mohms	.15 to .3
Operate time, 25°C		
Close (includes bounce) Max	ms	20
Close (includes bounce) Typical	ms	13
Bounce on close, Max	ms	7
Release time (includes arc time at max. break current)	ms	12
Insulation Resistance	Mohms	100 2/
Dielectric at sea level (leakage < 1mA)	VRMS	2,500
Shock	G's peak	20
Vibration, Sinusoidal (500-2000 Hz peak)	G's	15
Operating ambient Temp Range	°C	-55 to +85 3/
Storage ambient Temp Range	°C	-70 to +175
Weight, Typical	Kg (Lb)	0.44/(0.98)

1/ Auxillary contact rating - 2A, 24Vdc Resistive load, 100,000 cycles. Minimum current is 100mA, 8V. The auxiliary contact is mechanically linked to the main power contacts.

2/ 50 Mohms after life.

3/ Contactor can operate up to 125°C in special cases - contact GIGAVAC for details.

PART NUMBER SYSTEM	
GX200	B C A
Coil Voltage B = 12 Vdc, internal coil suppression C = 24 Vdc, internal coil suppression F = 48 Vdc, internal coil suppression	
Coil Termination A = Flying leads, 38 cm (15 in) B = Flying leads, 61 cm (24 in) C = Flying leads, 122 cm (48 in)	
Auxiliary Contact (same length as coil wire selection) Blank = None B = SPST, Normally Open	

POWER CONNECTION

HARDWARE INCLUDED:
STAINLESS M8X1.25 STUD
STAINLESS M8X1.25 NUT
STAINLESS LOCK WASHER
STAINLESS FLAT WASHER

TORQUE 90 in-lb MAX

CASE MATERIAL

25-30% GF Nylon 6/6
UL94 V-O

MOUNTING

M5 or NO.10 SCREWS

TORQUE 1.7-4Nm [15-35in-lb]

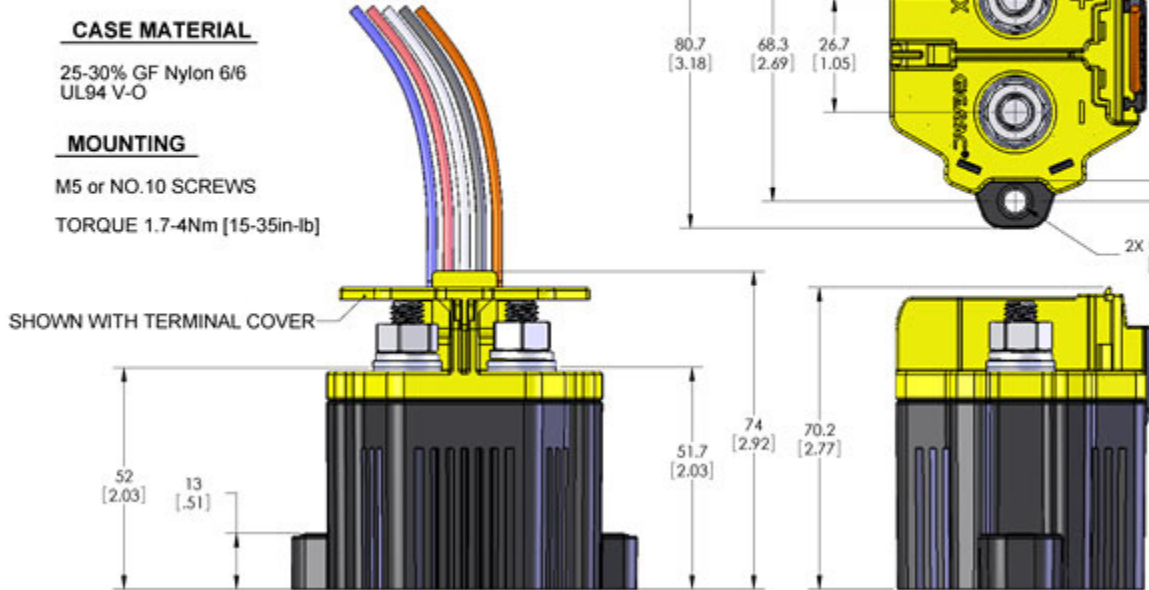
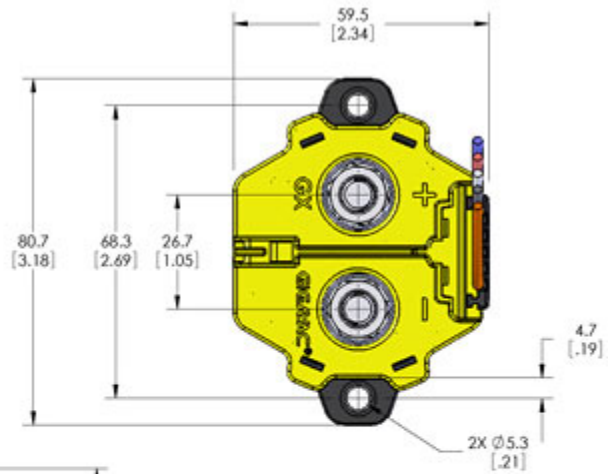

DC COIL SUPPRESSION

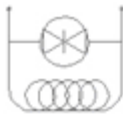

A/C COIL



BLACK X2
COIL (-)

WHITE T2
AUX

AUXILIARY OPTION

RED X1
COIL (+)

BLUE T1
AUX

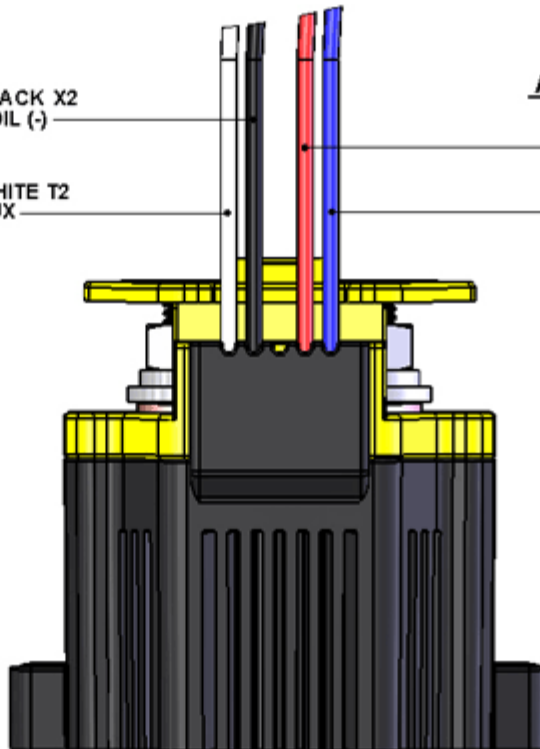

WIRE SPEC: SILICONE, 20AWG, -40C-150C, UL: VW-1

Power contacts

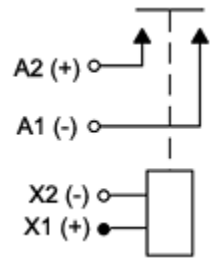

Auxiliary contacts (optional)

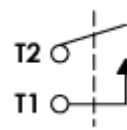

To Lift and Remove the Terminal Safety Cover:

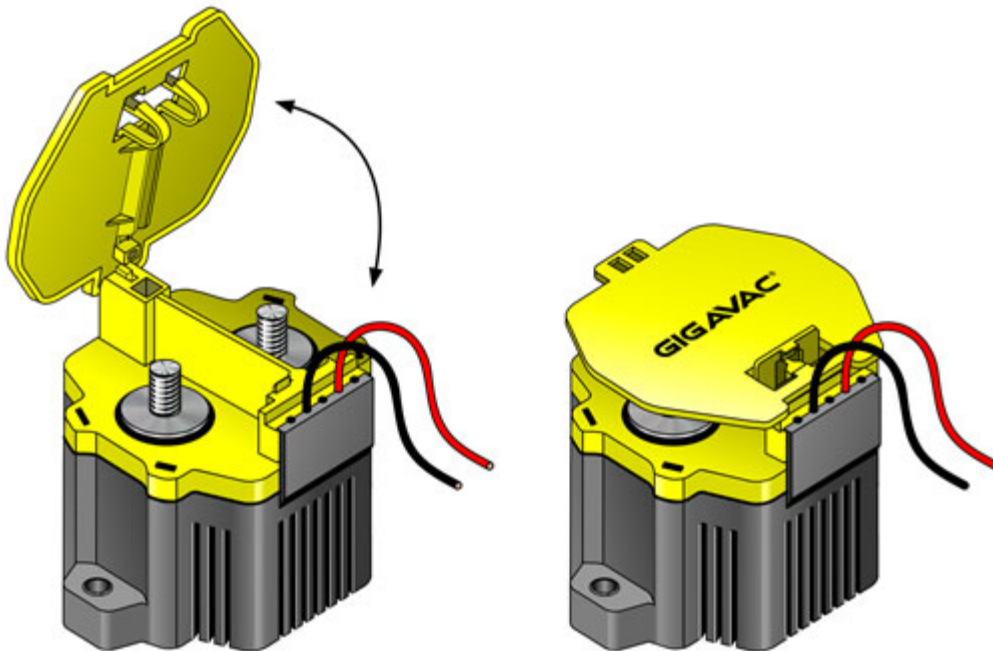

- A. Push the tab of the cover to unlock it.
- B. Lift the cover as shown. It will pivot on the rear pin.
- C. If needed, remove the cover by pulling it straight back as shown.
- D. To place the cover back in its original position, replace the cover as shown. Follow step C in reverse.
- E. The cover can now pivot down to close.
- F. Make sure to push the locking tab into place.

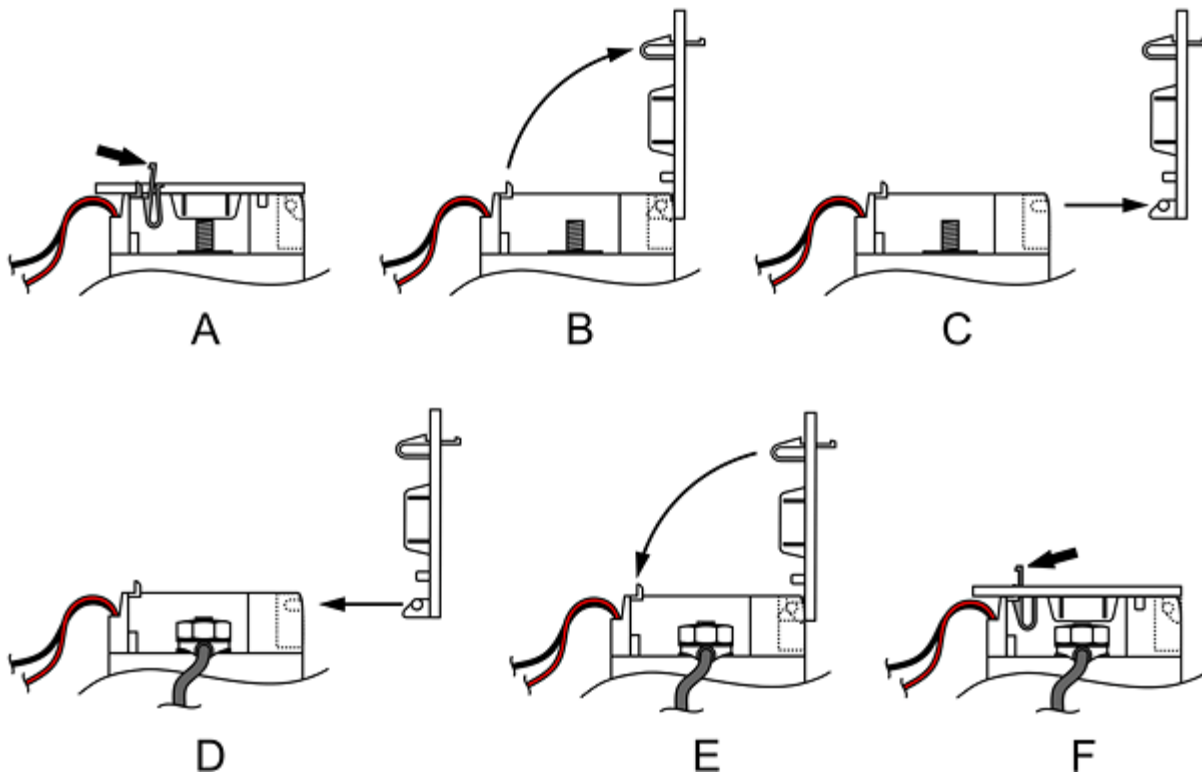

Application Information:

1. **WARNING** - When using more than one lug on a power terminal, make sure the primary power is closest to the contactor busbar, with the lower current lug on top, then the washer, then the lock washer, then the nut. **Improper order can cause severe over-heating resulting in the possible melting of the connecting cable insulation.**

2. [GX200 to EV200 Product Comparison](#)

3. [EPIC®](#) sealing technology

4. [Relay Schematics and Forms](#)

5. To learn more about contactor contact ratings, see discussion under “[Understanding Contactor Contact Ratings](#)” on [Compare Products](#) page.

6. For the more user friendly panel level terminations, you may want to check out the GIGAVAC EPIC® sealed 125 Amp [GX11](#), the 225 Amp [GX12](#), or the 350 Amp [GX14](#). The GX14 is nearly identical to the GX200 but has longer UL rated life and less maximum interrupt capability than the GX200. For a panel level terminal contactor with all of the GX200 ratings, [contact GIGAVAC](#).

* Kilovac is a registered Trade Mark of Tyco International. GIGAVAC does not sell the Kilovac branded EV200 contactor, but offers the GIGAVAC GX200 as a direct alternative that we feel is better because of the EPIC® seal and other design enhancements. [Compare the products](#).

02/29/12