

GX11

12 to 750 Vdc/Vac

EPIC® Hermetic Sealed DC and AC Contactor - 150+ Amp Power Switching RoHS Compliant, all date codes



Patent Pending



File E320908

All contact ratings and coil versions may not be UL recognized.

Contact GIGAVAC for a copy of the applicable sections of the test report.

FEATURES

- **Chassis level UL508 sized power terminals** – No need for specially routed power cables, special bus bars, or special lugs.
- **Rugged EPIC® Seal rated to 175°C** – Reduced risk of fire or meltdown in over current conditions. The same technology used for advanced aerospace programs.
- **Hermetically Sealed** – Designed to meet: UL1604 for Class I & II, Div 2 and Class III for use in hazardous locations, IP67 for temporary water immersion for 30 min, SAE J1171 - external ignition protection, and ISO8846 for protection against ignition around flammable gasses.
- **Optional High Efficiency Dual DC Coils** – Very low 12 or 24 VDC continuous coil power with no EMI emissions or cross-talk on your system control power. Ideal for battery powered systems or where low power is needed.
- **Built-in coil suppression for all DC coils** – Saves you engineering time and parts cost to add external coil suppression.
- **Stainless steel hardware and mounting inserts**, for years of corrosion free service.
- **UL508 ambient compliant to 75°C** but can operate continuously at 85° C with a higher terminal temperature rise of 60°C. Can also operate up to 125°C in special cases - contact GIGAVAC for details.
- **Not position sensitive** – can be mounted in any position for ease of installation.

UL COMPLIANT DC & AC ESTIMATED CONTACT POWER SWITCHING RATINGS

Make & Break Resistive Current with 1/0 cable and 50° terminal temp rise	Contact Voltages & Life Cycle Ratings DC or 50/60 Hz AC					
	24 V	48 V	72 V	120 V	350 V	750 V
150A - (75° C Ambient) 1/	150,000	100,000	40,000	20,000	7,500	1,200
125A - (75° C Ambient) 1/	180,000	120,000	48,000	24,000	9,000	1,440
100A - (75° C Ambient) 1/	225,000	150,000	60,000	30,000	11,250	1,800
75A - (75° C Ambient) 1/	300,000	200,000	80,000	40,000	15,000	2,400
50A - (75° C Ambient) 1/	435,000	290,000	116,000	58,000	21,750	3,480
30A - (75° C Ambient) 1/	750,000	500,000	200,000	100,000	37,500	6,000
20A - (75° C Ambient) 1/	900,000	600,000	240,000	120,000	45,000	7,200
225A - (50° C Ambient) 2/	127,500	85,000	34,000	17,000	6,375	1,020
Max Break A, 2 cycles (75° C Ambient) 1/	2,500A	2,000A	1,500A	1,000A	900A	600A
Max Make, 10 cycles (75° C Ambient) 1/	1,400A	1,100A	800A	600A	500A	350A

Electrical life rating is based on resistive load with 27µH maximum inductance in circuit. Because your application may be different, we suggest you test the contactor in your circuit to verify life is as required.

End of life is defined as when the dielectric, insulation resistance or contact resistance exceeds the specifications listed.

If your application requires a higher current rating, you may want to consider the GIGAVAC 225 Amp [GX12 EPIC® Sealed Contactor](#) or the 350 Amp [GX14 EPIC® sealed contactor](#).

1/ Assumes UL508 ratings with 1/0 cables, UL508 max ambient temperature of 75°C as shown, and max. UL508 terminal temperature rise of 50°C.

At 85°C ambient, contactor can also meet all of its 75°C specifications but the terminal temperature can rise can be up to 60°C, which is higher than the 50°C rise allowed by UL508 and can be higher than some cable insulation ratings.

2/ Assumes UL508 ratings with 1/0 cables, at a lower 50°C UL508 ambient temperature, and max. UL508 terminal temperature rise of 50°C.

UL COMPLIANT DC & AC CONTACT CURRENT CARRY RATINGS		
		75°C / 50°C
Cable size 1/		1 / 0
Continuous, UL508 Max 1/	Amp	150 / 225
10 seconds (1 time)	Amp	375 / 560
100 Seconds (1 time)	Amp	240 / 360
300 Seconds (1 time)	Amp	200 / 300
Starter Carry – Inrush 250 ms (10 repeats 1/ 2/)	Amp	NA / 2,000
Starter Carry - Cranking 10 sec (10 repeats 1/ 2/)	Amp	NA / 500
Maximum terminal Temp, Continuous	Deg C	175
Maximum terminal Temp, Intermittent	Deg C	225

If your application requires a higher current rating, you may want to consider the GIGAVAC 225 Amp [GX12 EPIC® Sealed Contactor](#) or the 350 Amp [GX14 EPIC® sealed contactor](#)..

1/ Assumes UL508 ratings with 1/0 cables, ambient maximum UL 508 temperature of 75°C, and maximum UL508 terminal temperature rise of 50°C. Contactor can also carry the higher current as shown for 50°C ambient, and meet all of the UL508 temperature rise requirements.

At 85°C ambient, contactor can also meet all of its 75°C specifications but the terminal temperature can rise can be up to 60°C, which is higher than the 50°C rise allowed by UL508 and can be higher than some cable insulation ratings.

The maximum terminal temperature rating of the contactor is 175°C, which means much higher currents than shown can be carried and switched. However, this temperature is much higher than most cable insulation ratings, which mean busbars must be used. Contact GIGAVAC for assistance for higher current applications using this contactor.

2/ Rating consists of combined inrush + cranking current at the times specified, with 2 seconds off between cycles. This is higher current than is required for UL1107 for marine battery switches.

COIL RATINGS - see below for high efficiency coils							
Nominal Volts	12Vdc	24Vdc	48Vdc	72Vdc	120Vdc	120Vac, 50/60Hz	240Vac, 50/60Hz
Coil P/N Designation	B	C	F	H	J	K	L
Max Volts	14	28	56	84	140	140	280
Pick-up, Volts, Max	7.5	15	28	46	72	80	144
Hold, Volts, Min	4	9	18	28	46	46	92
Drop-Out, Volts, Min	0.5	0.5	1.8	2.7	4.5	4.5	9
Coil Resistance @ 25°C (Ohms ±10%)	17	85	335	850	2125	N/A	N/A
Coil Current, mA, Max at nominal Voltage	700	280	150	90	56	56	28
Coil Back EMF (volts) - Built in suppression 1/	55	55	100	150	288	N/A	N/A

Ratings are at worse case temperature extremes, except coil resistance and current are at 25°C.

1/ DC coils have built-in coil suppression. The use of additional external coil suppression can slow the release time and invalidate the life cycle ratings, or can cause the contactor not to be able to interrupt the maximum current specified. If lower coil back EMF is required, please contact GIGAVAC for assistance.

OPTIONAL HIGH EFFICIENCY DUAL-COIL RATINGS		
Nominal Coil Voltage	12Vdc	24Vdc
Coil P/N Designation	S	T
Coil Voltage (Max) 1/	15	30
In-Rush Current Max (75 ms) – Amps 2/ 3/	1.8	0.9
Hold Current after in-rush (Avg.) - Amps 3/	0.090	0.045
Hold Power after in-rush (Avg.) – Watts 3/	1.1	1.1
Pick-up, Volts, Max 2/ 4/ 5/	9	15
Hold, Volts, Min 5/	5	10
Drop-Out, Volts, Min 5/	1.0	1.5
Coil Back EMF (volts) 6/	45	45

Ratings are at 25°C. For specific values at other temperatures, please [contact GIGAVAC](#).

1/ Because the contactor is operated by a coil that changes resistance with temperature, the maximum coil voltage will be lower than indicated at temperatures above 25C, and higher than indicated at temperatures below 25C.

2/ Contactor has two coils. Both are used for pull-in, and then in approximately 75 milliseconds, one coil is electronically removed from the coil drive circuit. The remaining coil supplies low continuous hold power sufficient for the contactor to meet all of its specified performance specifications. This provides the lowest coil power possible without the use of PWM electronics that have been known to cause EMI emissions and/or cross-talk on your system control power.

3/ Because the contactor is operated by a coil that changes resistance with temperature, and because Nominal Coil voltage has been assumed for the In-Rush, Hold Current and Hold Power specifications, Current/Wattage will be lower than indicated at temperatures above 25C and higher than indicated at temperatures below 25C.

4/ For Pick-up testing of contactors with dual coils, the voltage can not be ramped up slowly, but must be applied instantly to at least the maximum pull-in voltage or current. Otherwise, the contactor will not pick-up.

5/ Because the contactor is operated by a coil that changes resistance with temperature, Pick-up Voltage, Hold Voltage, and Drop Out Voltage will be lower than indicated at temperatures below 25C and higher than indicated at temperatures above 25C.

6/ These DC coils have built-in coil suppression. The use of additional external coil suppression can slow the release time and invalidate the life cycle ratings, or can cause the contactor not to be able to interrupt the maximum current specified. If lower coil back EMF is required, please [contact GIGAVAC](#) for assistance.

PRODUCT SPECIFICATIONS		
Specifications	Units	Specifications
Contact Arrangement (main)	Form X	SPST-NO
Contact Arrangement (Auxiliary) 1/	Form A	SPST-NO
Mechanical Life	cycles	1 million
Contact Resistance		
Max @ rated carry current	mohms	.4
Typical @ rated carry current	mohms	.15 to .3
Operate time, 25°C		
Close (includes bounce) Max	ms	20
Close (includes bounce) Typical	ms	13
Bounce on close, Max	ms	7
Release time (includes arc time at max. break current)	ms	12
Insulation Resistance	Mohms	100 2/
Dielectric at sea level (leakage < 1mA)	VRMS	2,500
Shock	G's peak	20
Vibration, Sinusoidal (500-2000 Hz peak)	G's	15
Operating ambient Temp Range	°C	-55 to +85 3/
Storage ambient Temp Range	°C	-70 to +175
Weight, Typical	Kg (Lb)	0.50/(1.1)

1/ Auxillary contact rating - 2A, 24Vdc Resistive load, 100,000 cycles. Minimum current is 100mA, 8V. The auxiliary contact is mechanically linked to the main power contacts.

2/ 50 Mohms after life.

3/ Contactor can operate up to 125°C in special cases - contact GIGAVAC for details.

PART NUMBER SYSTEM

GX11

B C A

Coil Voltage

B = 12 Vdc with internal coil suppression
S = 12Vdc, Dual-Coil High Efficiency Option with internal coil suppression
C = 24 Vdc with internal coil suppression
T = 24 Vdc, Dual-Coil High Efficiency Option with internal coil suppression
F = 48 Vdc with internal coil suppression
H = 72 Vdc with internal coil suppression
J = 120 Vdc with internal coil suppression
K = 115 VAC, 50/60 Hz
L = 240 VAC, 50/60 Hz

Coil Termination

A = Flying leads, 38 cm (15 in)
B = Flying leads, 61 cm (24 in)
C = Flying leads, 122 cm (48 in)

Auxiliary Contact (same length as coil wire selection)

Blank = None
B = SPST, Normally Open

MOUNTING

M5 or NO.10 SCREWS
 TORQUE 1.7-4Nm [15-35in-lb]

CASE MATERIAL

40-50% GF NYLON 6/6
 UL94 V-0

POWER TERMINALS

HARDWARE INCLUDED:
 STAINLESS M8X1.25 BOLT
 STAINLESS M8X1.25 NUT
 STAINLESS LOCK WASHER
 STAINLESS FLAT WASHER
 TORQUE 11-23Nm [100-200 in-lb]

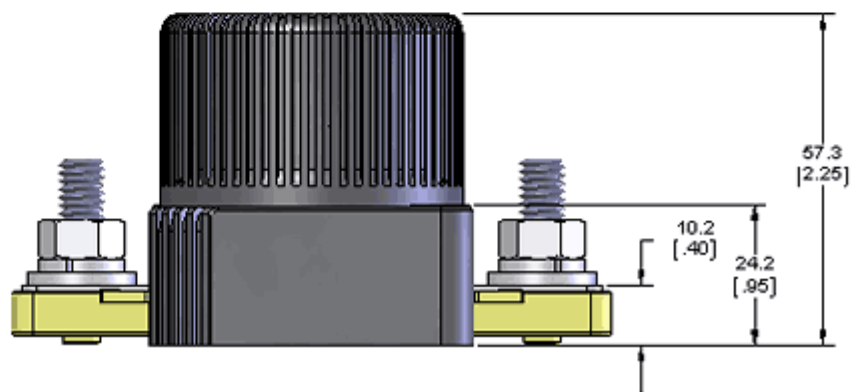
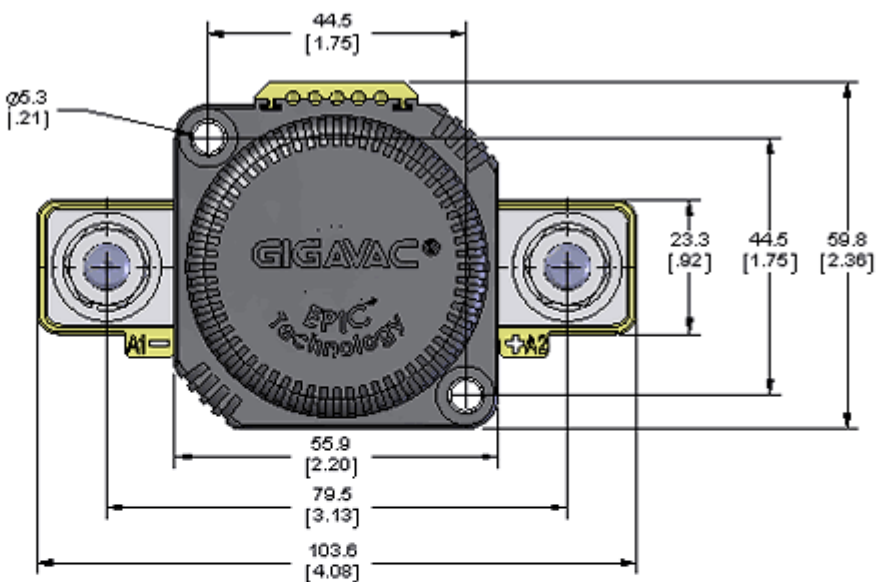

The polarity of the power terminals was previously shown reverse from what is correct and what is now indicated. The polarity is important only for switching the "Maximum Break, 2 cycles" when the voltage is over 100 Vdc.

STANDARD SINGLE DC COIL WITH INTERNAL SUPPRESSION

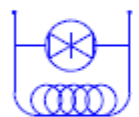

A/C COIL



AUXILIARY OPTION

BLACK X2 COIL (-)
 RED X1 COIL (+)
 ORANGE T3 AUX - NC
 WHITE T2 AUX - COM
 BLUE T1 AUX - NO

OPTIONAL HIGH EFFICIENCY DUAL DC COIL WITH INTERNAL SUPPRESSION

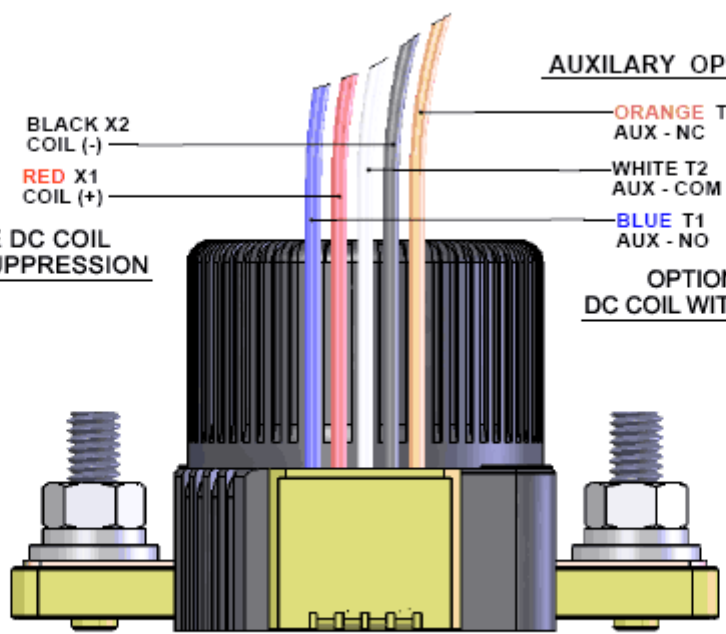
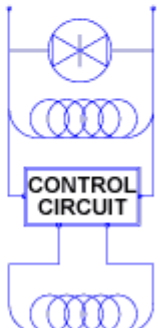

WIRE SPEC: SILICONE, 22AWG, -40C-150C, UL: VW-1

Power contacts

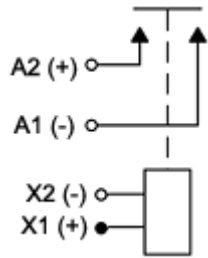

Auxiliary contacts (optional)

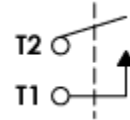

Application Information:

1. **WARNING** - When using more than one lug on a power terminal, make sure the primary power is closest to the contactor busbar, with the lower current lug on top, then the washer, then the lock washer, then the nut. **Improper order can cause severe over-heating resulting in the possible melting of the connecting cable insulation.**

2. [EPIC®](#) sealing technology

3. [Relay Schematics and Forms](#)

03/23/10



GIGAVAC® - P.O. Box 4428 - Santa Barbara, CA 93140-4428 - ph +(805) 684-8401 - +(805) 755-2000
fx +(805) 684-8402 - info@gigavac.com - www.gigavac.com - ©Copyright 2003-2010 GIGAVAC, LLC.