

# GH2 - GH4 - GH6

# 8 kV

GH2: No Load Switching - GH4: Make & Break Load Switching - GH6: Make Only Load Switching  
 RoHS Compliant, date code 0601 and later

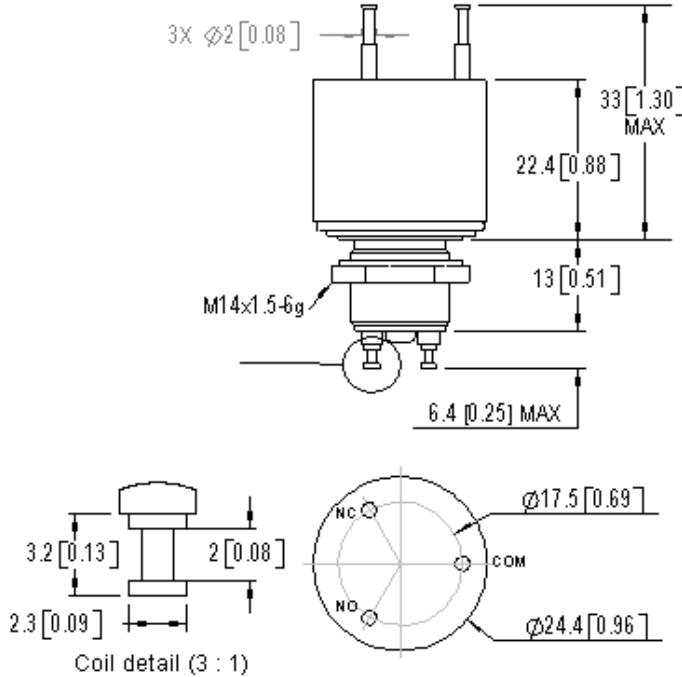

| FEATURES   |  |
|--|--|
| <b>GH 8kV SERIES</b>   |  |
| <ul style="list-style-type: none"> <li>Easy to mount threaded base with jam nut</li> <li>User interchangeable coils provide for driver versatility</li> <li>Meets or exceeds standards set in MIL-R-83725</li> </ul> |  |
| <b>GH2 - No Load Switching</b>   |  |
| <ul style="list-style-type: none"> <li>Low, stable contact resistance minimizes voltage drop in sensitive circuits</li> <li>High carry current, 25Adc continuous, in a small package</li> </ul>                      |  |
| <b>GH4 - Make &amp; Break Load Switching</b>   |  |
| <ul style="list-style-type: none"> <li>Durable tungsten contacts for hot load switching*</li> <li>Vacuum dielectric for effective arc quenching when opening under load*</li> </ul>                                  |  |
| <b>GH6 - Make Only Load Switching</b>  |  |
| <ul style="list-style-type: none"> <li>Excellent for capacitive discharge and safety dump switch applications</li> <li>Can be modified to accommodate customer specified cables and connectors</li> </ul>            |  |

\*Consult factory for load switching apps.

| PRODUCT SPECIFICATIONS   |              |             |             |             |
|--|--------------|-------------|-------------|-------------|
| Contact & Relay Ratings  | Units        | GH2         | GH4         | GH6         |
| Contact Form   |              | C           | C           | C           |
| Contact Arrangement  |              | SPDT        | SPDT        | SPDT        |
| Voltage, Test Max., Contacts & to Base (15 $\mu$ A Leakage Max., dc or 60Hz) | kV Peak      | 10          | 10          | 10          |
| Voltage, Operating Max., Contacts & to Base (15 $\mu$ A Leakage Max.)        |              |             |             |             |
| dc or 60 Hz  | kV Peak      | 8           | 8           | 8           |
| 2.5 MHz  | kV Peak      | -           | -           | -           |
| 16 MHz   | kV Peak      | -           | -           | -           |
| 32 MHz   | kV Peak      | -           | -           | -           |
| Current, Continuous Carry Max  |              |             |             |             |
| dc or 60 Hz  | Amps         | 25          | 15          | 8           |
| 2.5 MHz  | Amps         | -           | -           | -           |
| 16 MHz   | Amps         | -           | -           | -           |
| 32 MHz   | Amps         | -           | -           | -           |
| Coil Hi-Pot (V RMS, 60 Hz)   | V            | 500         | 500         | 500         |
| Capacitance  |              |             |             |             |
| Across Open Contacts   | pF           | -           | -           | -           |
| Contacts to Ground   | pF           | -           | -           | -           |
| Resistance, Contact Max @ 1A, 28Vdc  | ohms         | 0.01        | 0.02        | 0.50        |
| Operate Time   | ms           | 6           | 6           | 6           |
| Release Time   | ms           | 6           | 6           | 6           |
| Life, Mechanical   | cycles       | 2 million   | 2 million   | 1 million   |
| Weight, Nominal  | g (oz)       | 39 (1.4)    | 39 (1.4)    | 39 (1.4)    |
| Vibration, Operating, Sine (55-2000 Hz Peak)                                 | G's          | 10          | 10          | 10          |
| Shock, Operating, 1/2 Sine 11ms (Peak)                                       | G's          | 50          | 50          | 50          |
| Temperature Ambient Operating  | $^{\circ}$ C | -55 to +125 | -55 to +125 | -55 to +125 |

| COIL RATINGS                       |        |        |        |
|------------------------------------|--------|--------|--------|
| Nominal, Volts dc                  | 12     | 26.5   | 115    |
| Pick-up, Volts dc, Max.            | 8      | 16     | 80     |
| Drop-Out, Volts dc                 | .5 - 5 | 1 - 10 | 5 - 50 |
| Coil Resistance (Ohms $\pm 10\%$ ) | 80     | 335    | 6000   |

Ratings listed are for 25 $^{\circ}$ C, sea level conditions

For more information, refer to [Relay User Instructions](#)

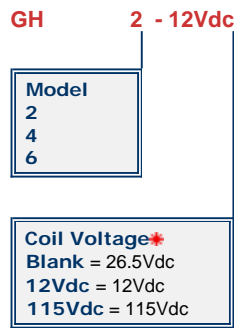

\*Order the relay with the coil voltage in the part number as shown above. The coil voltage will appear on the coil plate near the coil terminals rather than in the P/N on the relay.

09/06/11

