

Make & Break Switching - Limited (Contact Factory for Ratings)
 RoHS Compliant, date code 0701 and later

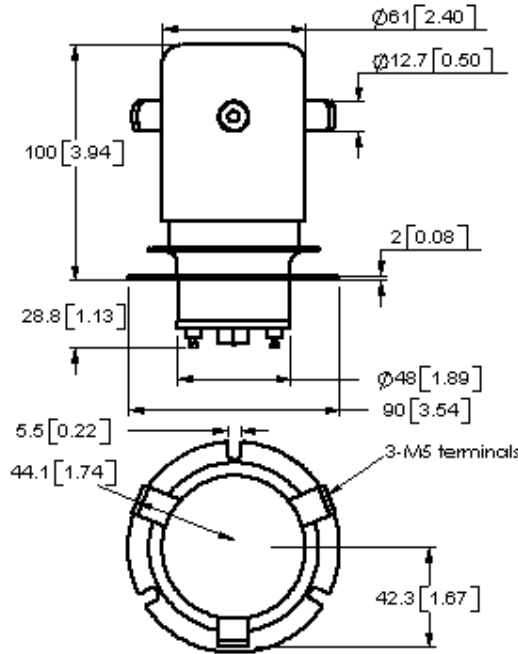

FEATURES	
• High carry current, 150 amps continuous, in a small package	
• Low, stable contact resistance minimizes loss in RF circuits	
• Threaded high voltage connections help make installation easy	
• Meets or exceeds standards set in MIL-R-83725	

PRODUCT SPECIFICATIONS		
Contact & Relay Ratings	Units	G52
Contact Form		C
Contact Arrangement		SPDT
Voltage, Test Max., Contacts & to Base (15 µA Leakage Max., dc or 60Hz)	kV Peak	30
Voltage, Operating Max., Contacts & to Base (15 µA Leakage Max.)		
dc or 60 Hz	kV Peak	25
2.5 MHz	kV Peak	15
13.56 MHz	kV Peak	10
32 MHz	kV Peak	7
Current, Continuous Carry Max		
dc or 60 Hz	Amps	150
2.5 MHz	Amps	120
13.56 MHz	Amps	75
32 MHz	Amps	30
Coil Hi-Pot (V RMS, 60 Hz)	V	500
Capacitance		
Across Open Contacts	pF	5
Contacts to Ground	pF	5
Resistance, Contact Max @ 1A, 28 Vdc	ohms	0.003
Operate Time	ms	100
Release Time	ms	15
Life, Mechanical	cycles	1 million
Weight, Nominal	g (oz)	1000 (35)
Vibration, Operating, Sine (55-500 Hz Peak)	G's	10
Shock, Operating, 1/2 Sine 11ms (Peak)	G's	30
Temperature Ambient Operating	°C	-55 to +125
Maximum Terminal Temperature	°C	200

COIL RATINGS	
Nominal, Volts dc	26.5
Pick-up, Volts dc, Max.	16
Drop-Out, Volts dc	1-10
Coil Resistance (Ohms ±10%)	60

Ratings listed are for 25°C, sea level conditions

For more information, refer to
[Relay User Instructions](#)

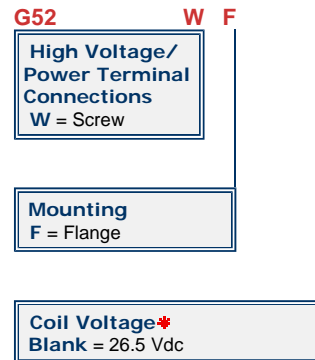

*Order the relay with the coil voltage in the part number as shown above. The coil voltage will appear on the coil plate near the coil terminals rather than in the P/N on the relay.