

G17 Heart Defibrillator Patient Relay

7.5 kV

Make Only Load Switching

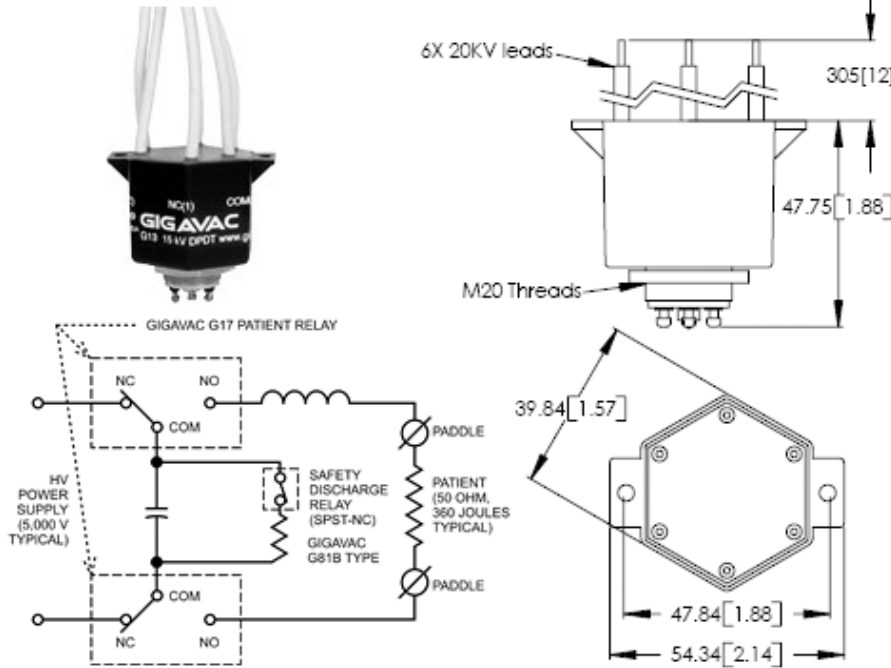

FEATURES	
•	SF-6 gas filled with tungsten contacts for sinusoidal waveform defibrillators
•	Flying leads for easy high voltage connection
•	Double pole, double throw
•	High power short duty coil for fast predictable operate time
•	Low cost alternate for use in many existing sinusoidal defibrillators
•	Refer to GIGAVAC G81A or G81B or G81C for safety discharge relays

PRODUCT SPECIFICATIONS		
Contact & Relay Ratings	Units	G17
Contact Form		2C
Contact Arrangement		DPDT
Voltage, Test Max., Contacts & to Base (15 µA Leakage Max., dc or 60Hz)	kV Peak	17
Voltage, Operating Max., Contacts & to Base (15 µA Leakage Max.)		
dc or 60 Hz	kV Peak	7.5
2.5 MHz	kV Peak	-
16 MHz	kV Peak	-
32 MHz	kV Peak	-
Current, Continuous Carry Max		
dc or 60 Hz	Amps	10
2.5 MHz	Amps	-
16 MHz	Amps	-
32 MHz	Amps	-
Coil Hi-Pot (V RMS, 60 Hz)	V	500
Capacitance		
Across Open Contacts	pF	0.5
Contacts to Ground	pF	1
Resistance, Contact Max @ 1A, 28 Vdc	ohms	1.0
Operate Time	ms	15
Release Time	ms	9
Life, Mechanical	cycles	1 million
Weight, Nominal	g (oz)	140 (5)
Vibration, Operating, Sine (55-500 Hz Peak)	G's	10
Shock, Operating, 1/2 Sine 1ms (Peak)	G's	50
Temperature Ambient Operating	°C	-20 to +65

COIL RATINGS	
Nominal, Volts dc	12
Pick-up, Volts dc, Max.	8
Drop-Out, Volts dc	.5 - 5
Coil Resistance (Ohms ±10%)	12

Ratings listed are for 25°C, sea level conditions

For more information, refer to
Relay User Instructions

G17 - 12Vdc

Coil Voltage*
12Vdc = 12 Vdc

Coil is intermittent duty,
max on time 100 ms, 10% duty cycle

*Order the relay with the coil voltage in the part number as shown above. The coil voltage will appear on the coil plate near the coil terminals rather than in the P/N on the relay.

Important Notice: Although the G17 has been designed for sinusoidal defibrillator applications as a patient discharge relay, not all defibrillator models are the same. GIGAVAC therefore makes no claims regarding the suitability of the G17 as a replacement relay for any existing application without testing. It is the buyer's sole responsibility to perform the required testing to verify that the G17 meets all of the functional and regulatory requirements before placing the G17 into service.

01/11/11